

beaufort

FREEBOARD EXTENSION SYSTEM

FOR RAPID AND SAFE ESCAPE



WHEN ONLY THE BEST WILL DO.



Beaufort has over 150 years of experience in the design, and manufacture of leading-edge products developed to protect in every environment.

With unparalleled commitment to innovation Beaufort is internationally recognised as world leader in the manufacture of high quality safety and survival clothing for defence and military personnel.

Beaufort's multi-discipline approach and state of the art production facilities ensure that every demand is catered for, from initial concept, design, qualification and manufacture to delivery and support.

Beaufort partners with some of the leading names in the safety industry to provide the most innovative products on the market. We have been working with James Fisher Defence for over 10 years to develop the Inflatable Freeboard Extender, a unique product designed to enhance survivability at sea for the submariner community.

The Inflatable Freeboard Extender (IFE) is used to assist submariners to rapidly escape from a distressed submarine in high sea states. It provides increased evacuee safety whilst preventing flooding of the submarine through the open escape hatches.

The Inflatable Freeboard Extender is an easy to operate, cost effective, and reliable escape system to complement your range of submarine safety equipment.

Product for TKMS Submarines in collaboration with JFD

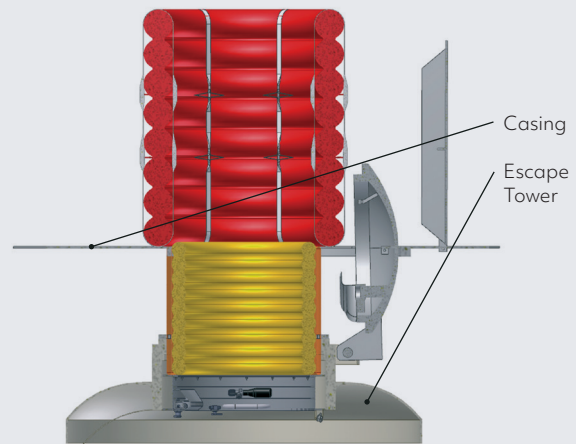

INTERNAL INFLATABLE FREEBOARD EXTENDER

The Internal IFE option is designed to be temporarily fitted to the inside of the submarine escape tower in the event of surface abandonment in high seas.

The system enables an escape rate of 2-3 submariners per minute from each of the casing hatches which would otherwise be unusable in emergency situations.

Internal IFE increases survivability

- The Internal IFE greatly improves safety of personnel during emergency evacuation
- The system design extends the freeboard of a submarine by 1m, crucial in times of emergency evacuation
- No modification is required to retrofit an IFE to an existing submarine, making it suitable for use on any vessel post-build

Operation

When required the IFE is lifted into the escape tower coaming. When in position below the escape hatch the IFE is locked in place and water sealed by inflating the sealing collar located around the fixed ring. Controls for the collar are located next to the lifting handle allowing them to be operated by thumb while the hand is still gripping the lifting handle.

Once locked in place the escape hatch is remotely opened and the IFE can then be deployed by opening a single valve. The IFE inflation system is automatically staged to inflate the skirt and support ring sections first and then the tower section. HP Air used for inflation can be taken directly from the Submarine gas supply or from a separately stowed cylinder.

The structure of the IFE incorporates strap fabric foot/hand holds which assist egress and tensions the tower structure as it inflates. The inflated tower forms a rigid structure.

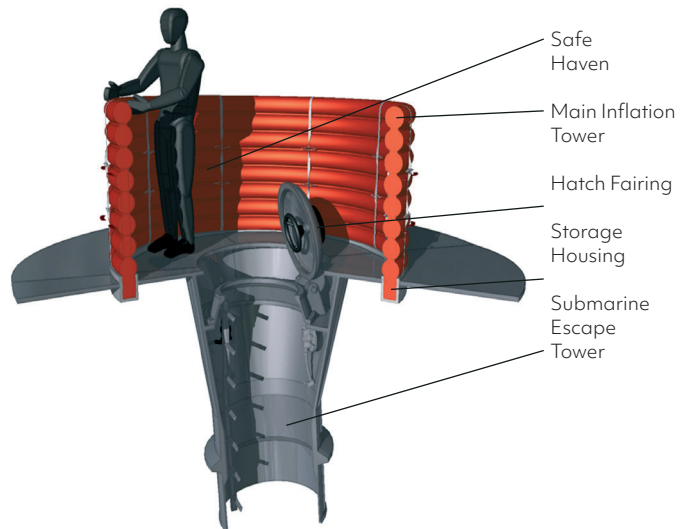
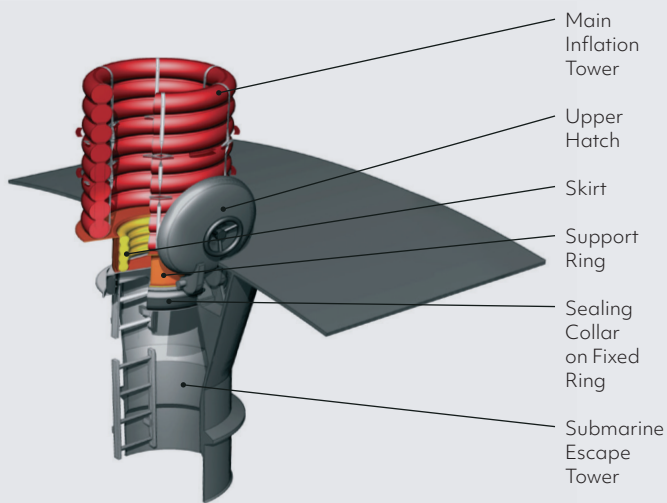

EXTERNAL INFLATABLE FREEBOARD EXTENDER

The external IFE option is designed as a permanent, reusable, escape option fitted between the rescue seat and the escape tower hatch of a submarine.

The IFE is deflated and stored in a GRP housing, which is bolted beneath the lip of the rescue seat under the casing. When stowed, the IFE is not sealed, instead it is open to external pressures as the submarine dives.

External IFE reduces risk during evacuation

- The External IFE is ideally incorporated at submarine build stage, which has the benefit of being a completely customised solution
- The system can be reused after an evacuation, ensuring optimal through-life value for money.
- The risk to the vessel or crew is significantly reduced when the hatch is open during evacuation;
- The External IFE provides a vital on-deck safe haven
- The system provides increased safety over an Internal IFE

Operation

When required the IFE is inflated by a single valve on a panel fitted in a convenient location within the escape tower. The control panel interface has been carefully designed to allow for fast and unambiguous operation during abandonment.

The IFE is inflated using air taken directly from the Submarine gas supply or via 250 bar air cylinder of standard size. This air is fed in at four points from this source, providing fast and even inflation.

After the recovery of the submarine the IFE can be deflated. This operation is controlled via valves on the control panel. During this process the IFE is drawn back into its housing and once in position catches secure it in place ready to be used again immediately.

An instruction panel detailing both the inflation and deflation procedures is fitted to the control panel.

The structure of the IFE incorporates strap fabric foot/hand holds which assist egress and tensions the tower structure as it inflates. The inflated tower forms a rigid structure.



beaufort

GET IN TOUCH

Email: defence-info@survitecgroup.com

Unit A, Aviator Industrial Park, Eric Fountain Road,
Ellesmere Port, CH65 1AX, UK

Copyright Notice

The copyright, trademarks, domain names and other intellectual property rights in all material and information in this presentation belongs to RFD Beaufort Group Limited. All rights are reserved.

Disclaimer

This document provides general information about Beaufort and its companies, its products and services, and summarises general capabilities and offerings which we deem to be of relevance to our customers. Whilst Beaufort has taken appropriate steps to ensure the accuracy of the information contained in this document, Beaufort gives no warranty regarding the accuracy or completeness of such information.

This presentation was prepared to provide information and does not constitute a contract. Beaufort reserves the right, without prior notice, to change, delete, supplement, or otherwise amend at any time the information, images, and offerings contained in this presentation, or other documents. Beaufort shall not be liable for any loss or damage of whatever nature (whether direct, indirect, consequential or other) that may arise as a result of any third party relying on the information contained in this document (but nothing in this disclaimer excludes liability for death or personal injury arising from negligence or any fraudulent misrepresentation).

For further detailed information, prices, terms and conditions, customers should contact Beaufort at defence-info@survitecgroup.com